

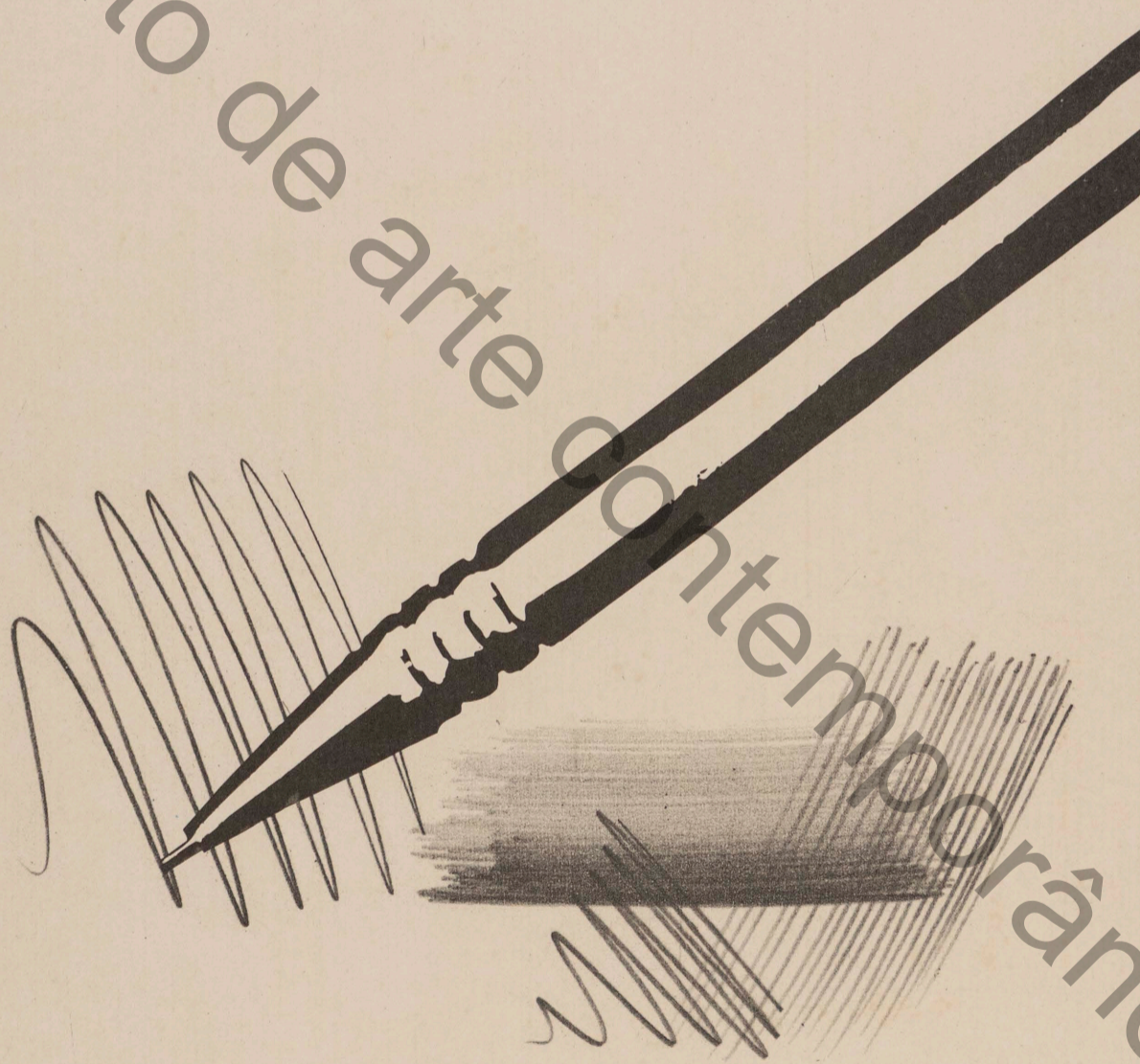

TECHNIQUE TÉCNICO

Layout
Lay-out

instituto de arte contemporânea



215 x 315 mm
50  - 120g/m²



instituto de arte contemporânea

instituto de arte contemporânea

instituto de arte contemporânea



instituto de arte contemporânea



Light work. registra a incidência de luz
entrando dentro de casa através de x cotões laranjas,
enquanto o porre reflete a movimentação do canal, das ruas.

A trama do tecido, ampliado na tela, permitindo - os
ver através dele, traz a tona a mesma impressão de
transparência, luz, membrana que as telas metálicas
concretizam nos esboços do an 80.70.

Sempre buscamos as mesmas realidades

Instituto de arte contemporânea

An abstract line drawing of a human face in profile, facing right. The drawing is composed of several overlapping, fluid lines in a light brown or sepia tone. The lines define the forehead, nose, cheek, and chin, with some areas appearing more defined than others, creating a sense of movement and depth. The background is a plain, light-colored surface.

instituto de arte contemporânea

instituto de arte contemporânea



instituto de arte contemporânea

An abstract line drawing of a face, rendered in a light brown or tan color. The drawing is composed of several overlapping, irregular outlines that define the forehead, eyes, nose, and mouth. The lines are thin and delicate, creating a minimalist and somewhat ethereal representation of a human face. The background is a plain, light beige color.

instituto de arte contemporânea

instituto de arte contemporânea

instituto de arte contemporânea

over

instituto de arte contemporânea

Muma

instituto de arte contemporânea



instituto de arte contemporânea



instituto de arte contemporânea

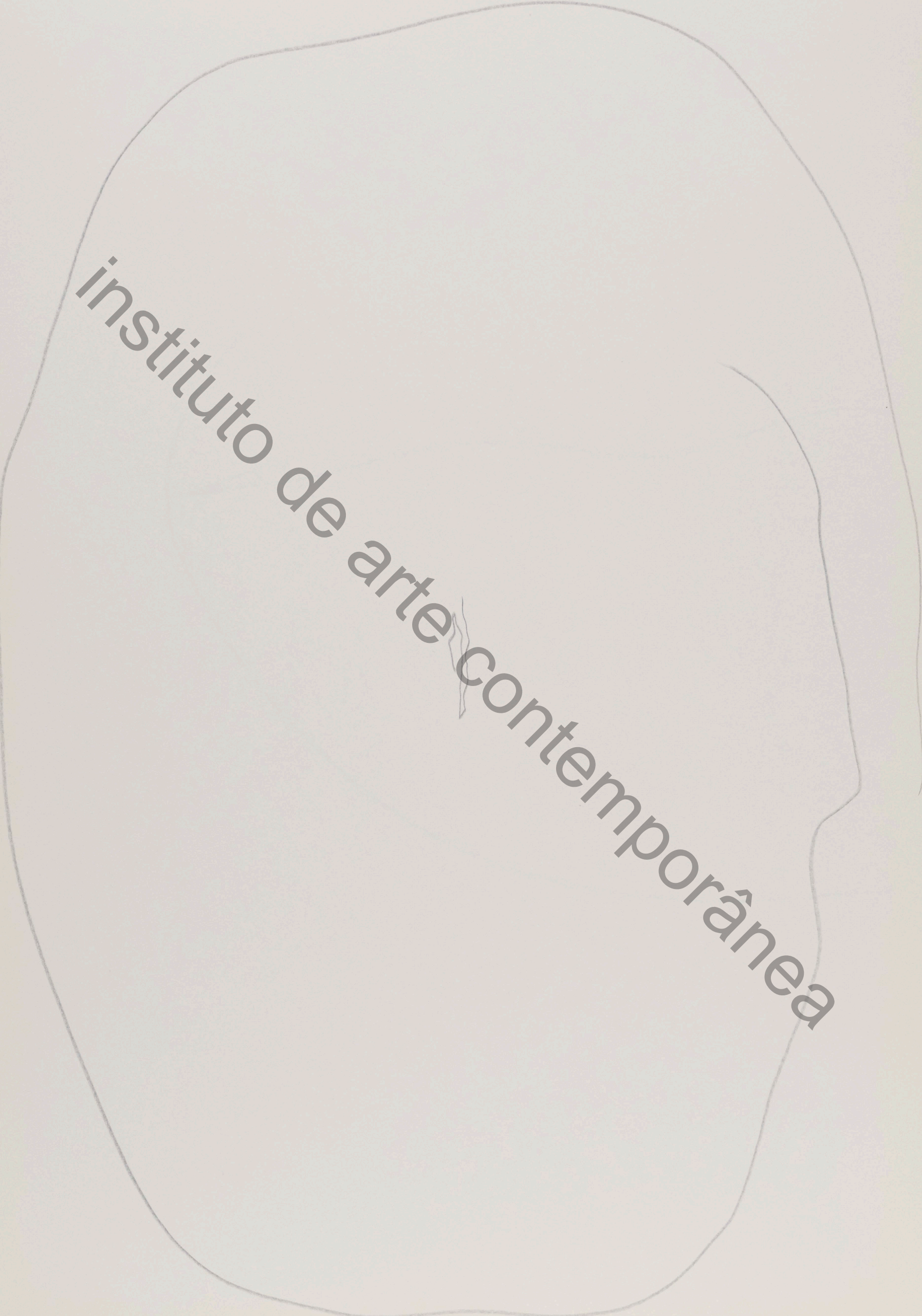

instituto de arte contemporânea

instituto de arte contemporânea

instituto de arte contemporânea



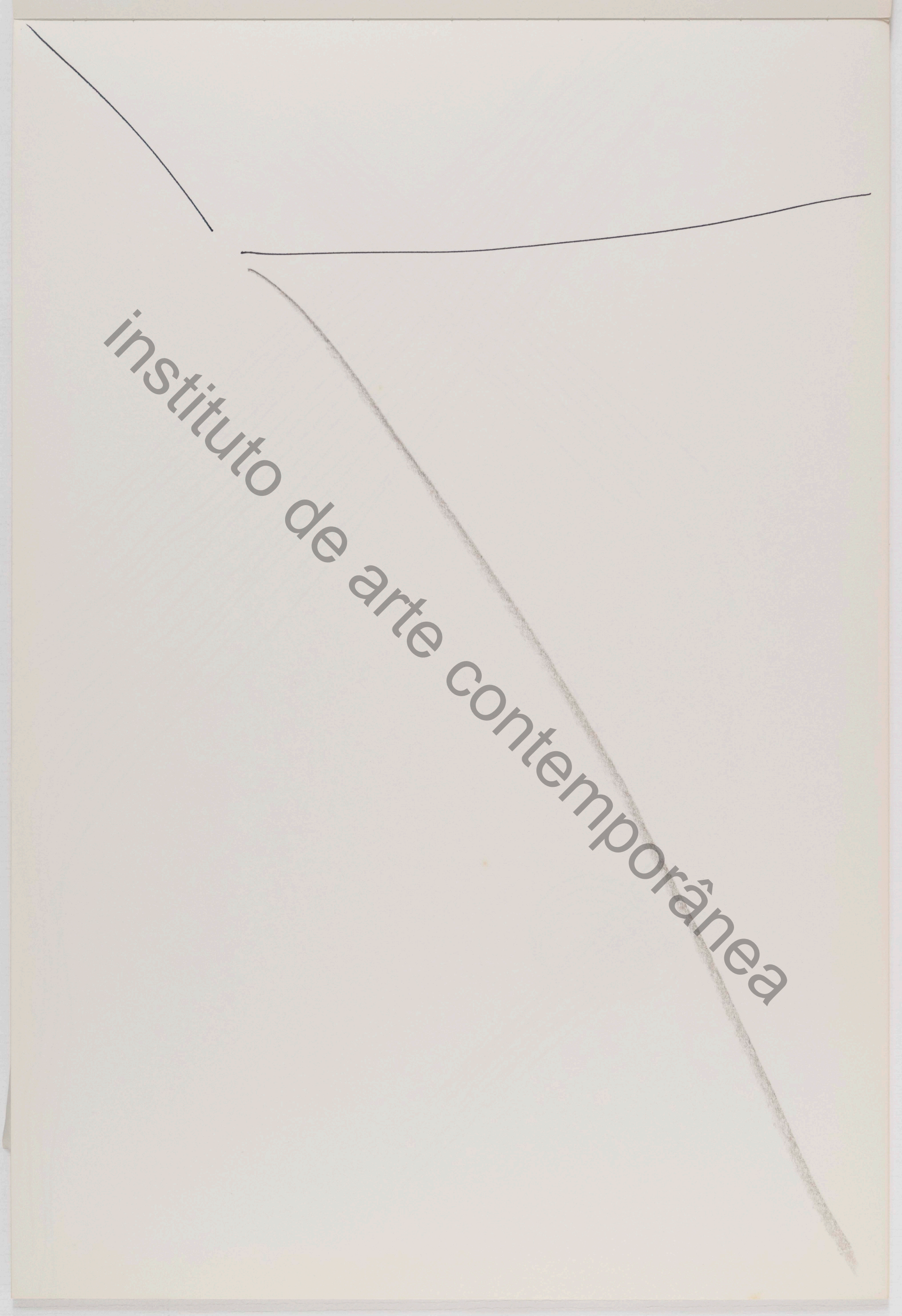

instituto de arte contemporânea

instituto de arte contemporânea

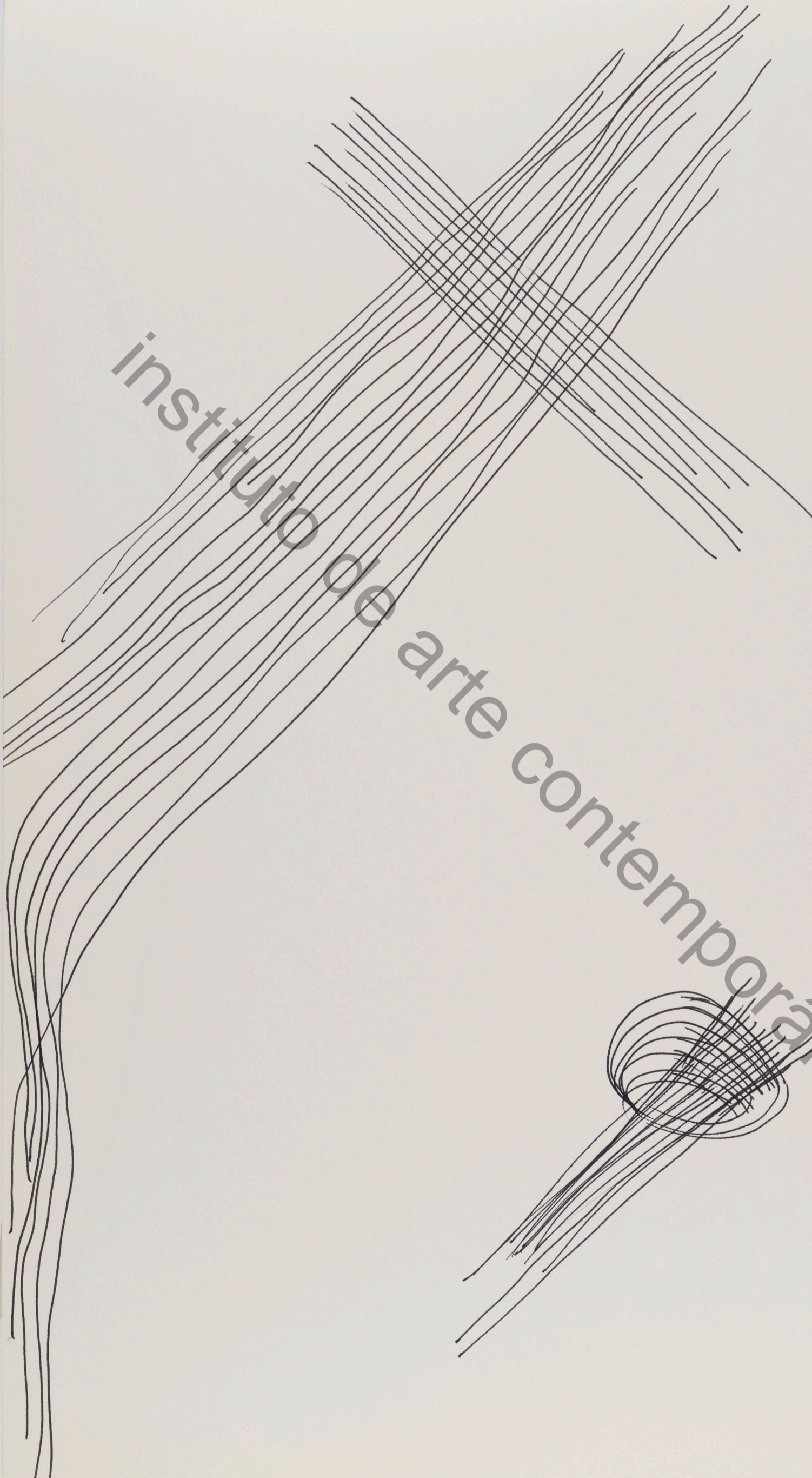

instituto de arte contemporânea

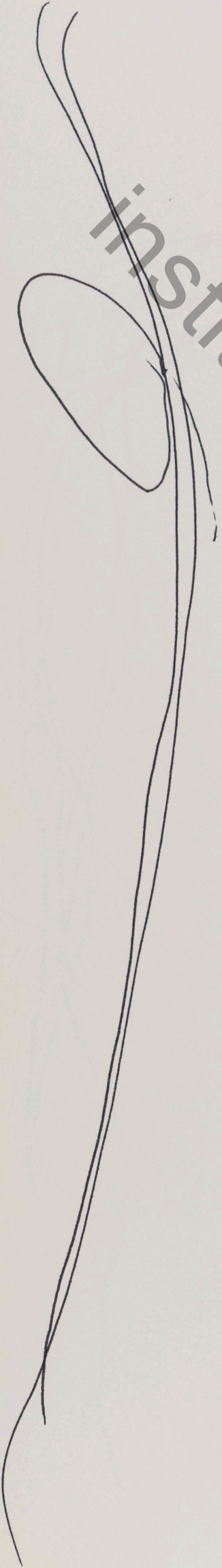



instituto de arte contemporânea

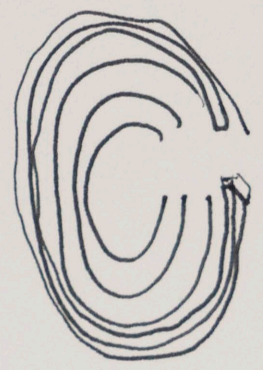

Instituto de arte contemporânea



Instituto de arte contemporânea

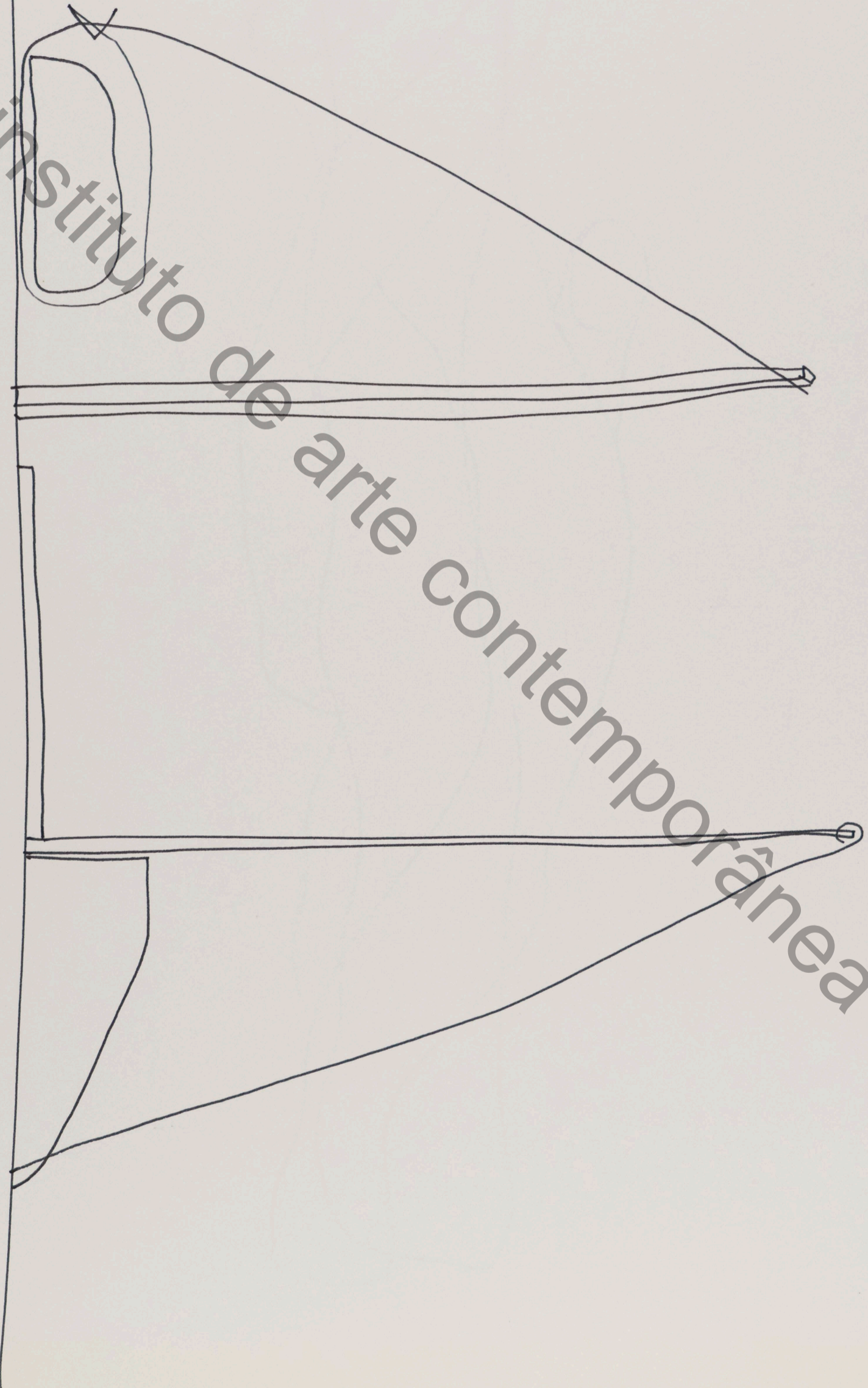

instituto de arte contemporânea



instituto de arte contemporânea

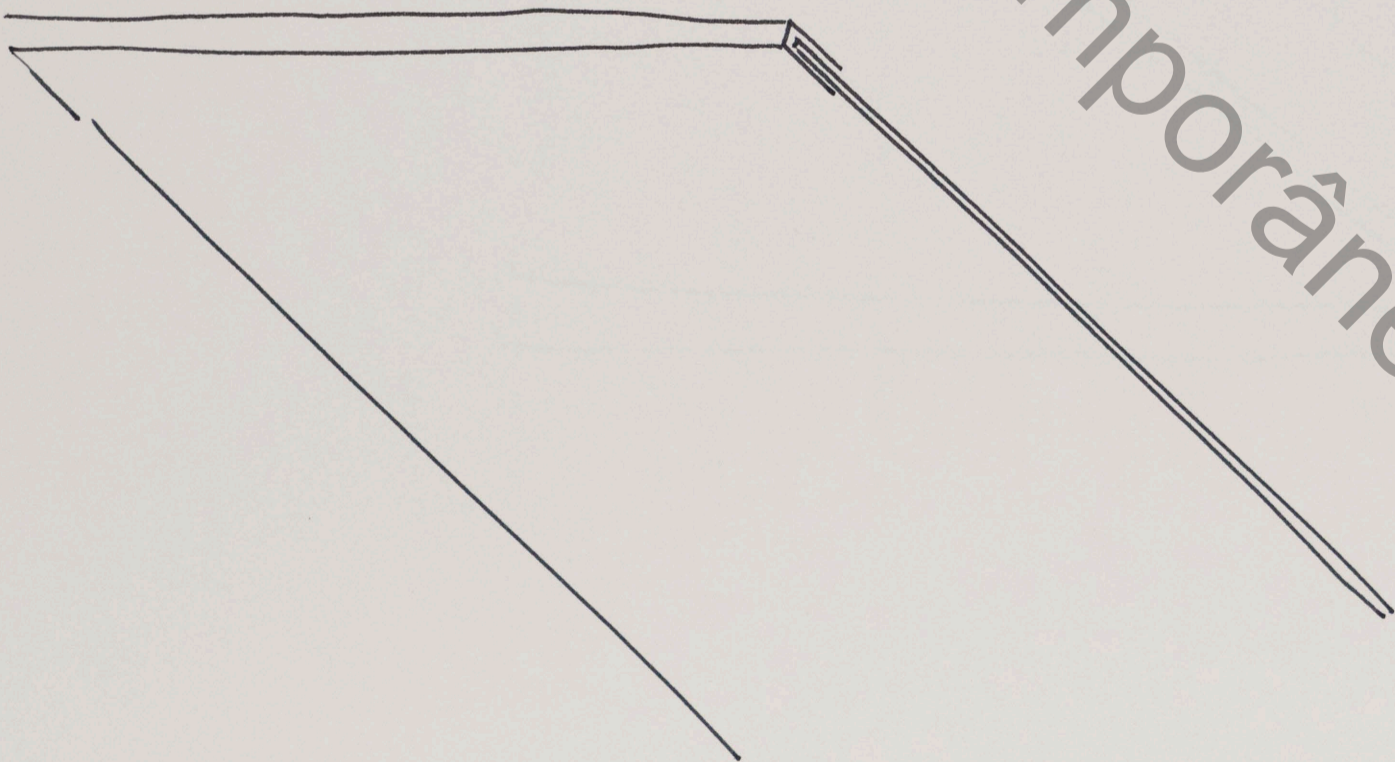

instituto de arte contemporânea

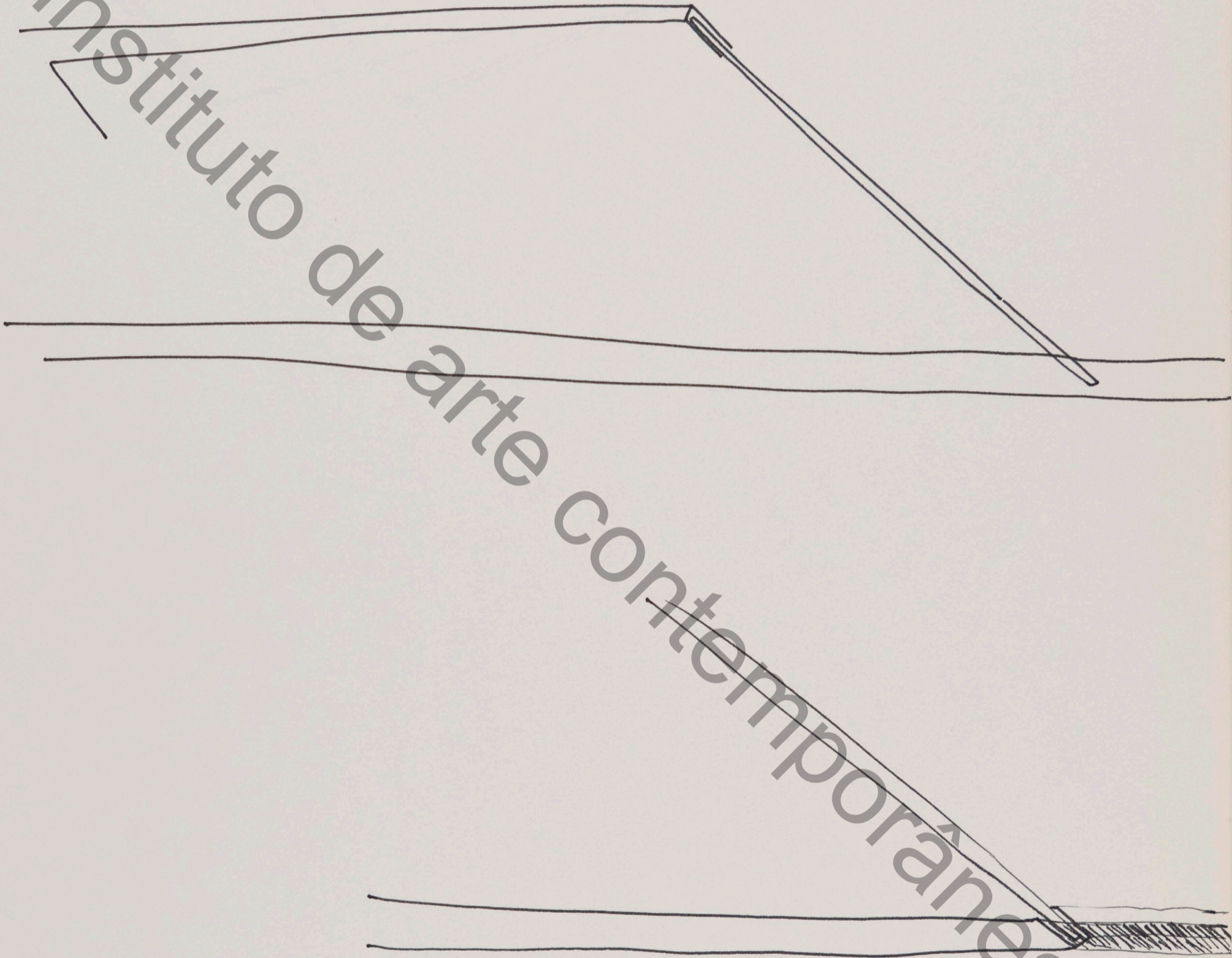

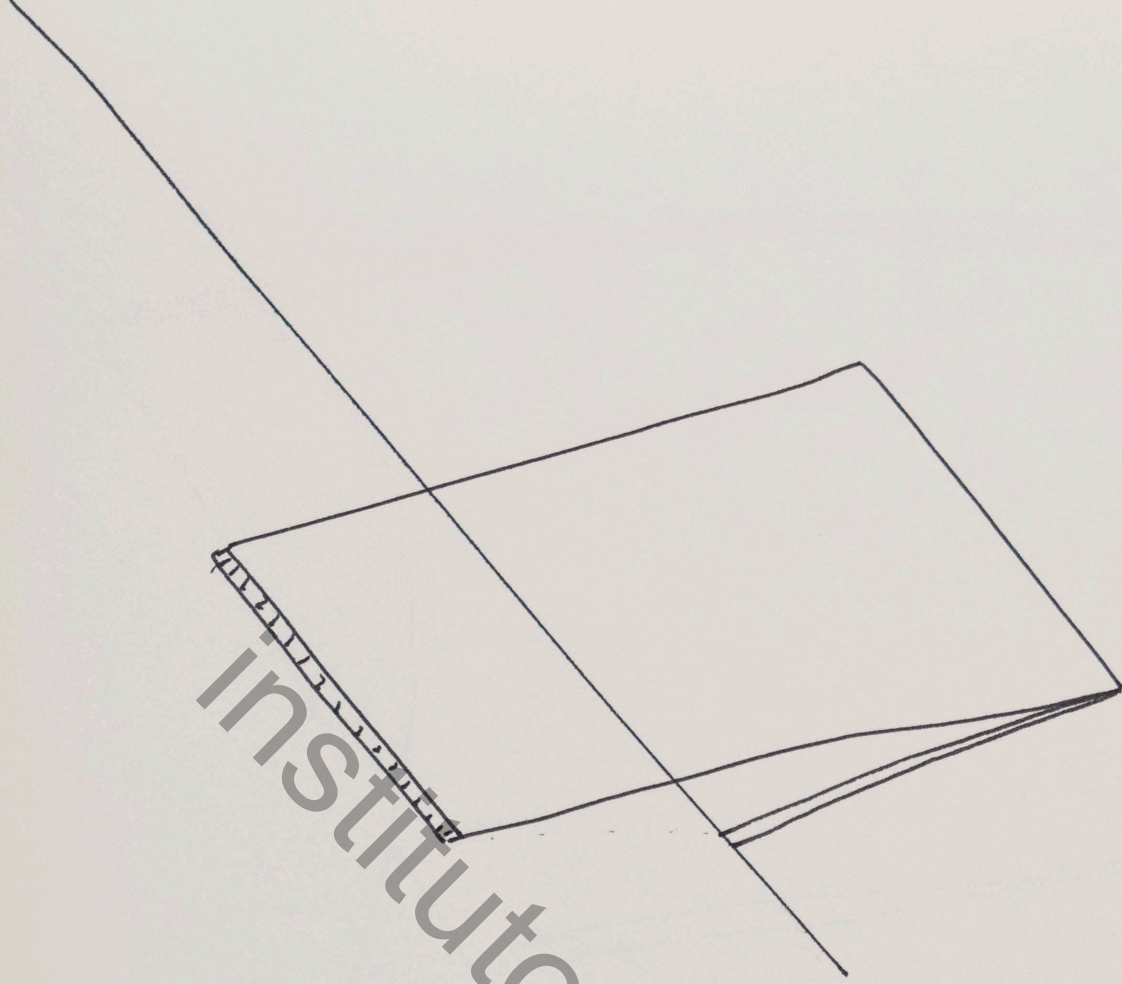

Instituto de arte contemporânea



Instituto de arte contemporânea



c

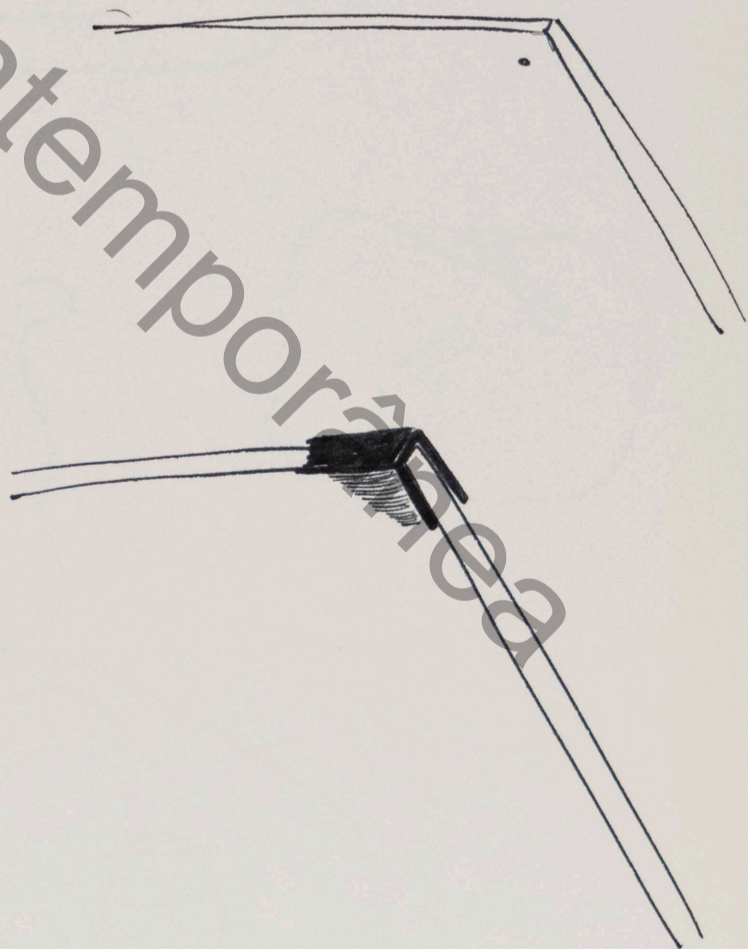
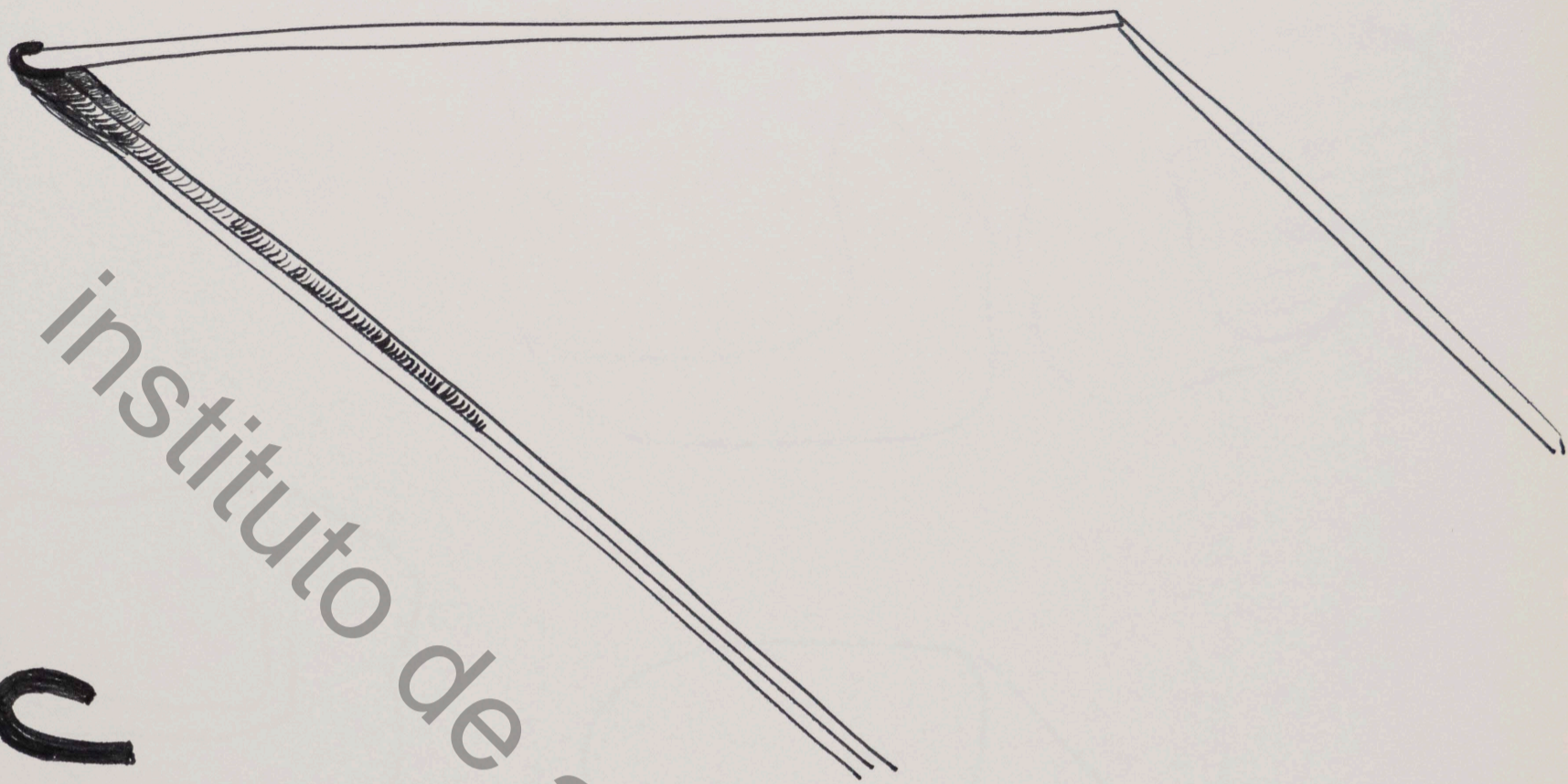

instituto de arte contemporânea

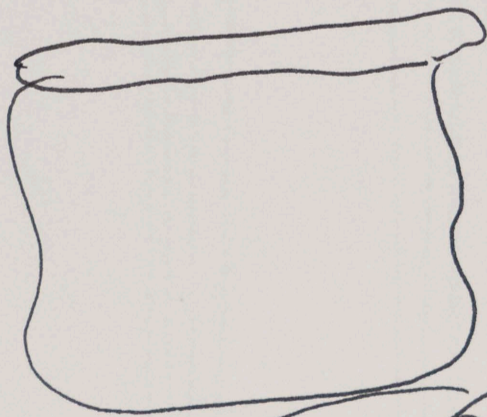
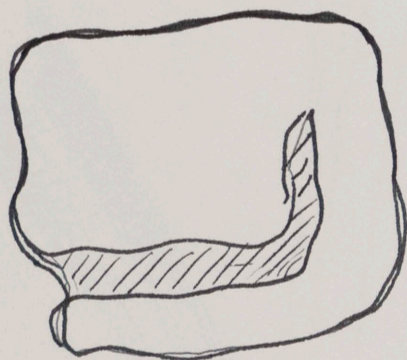
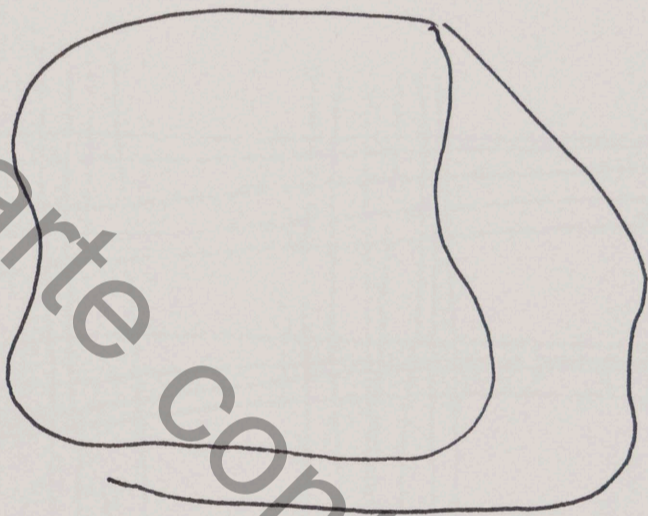
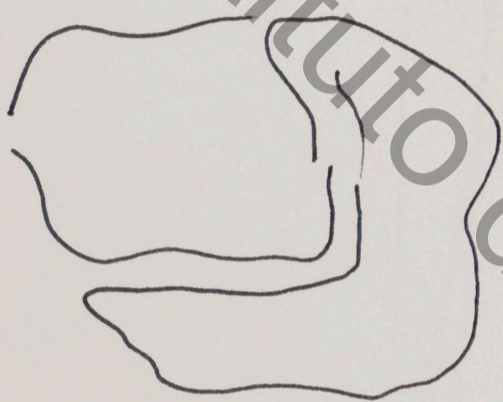
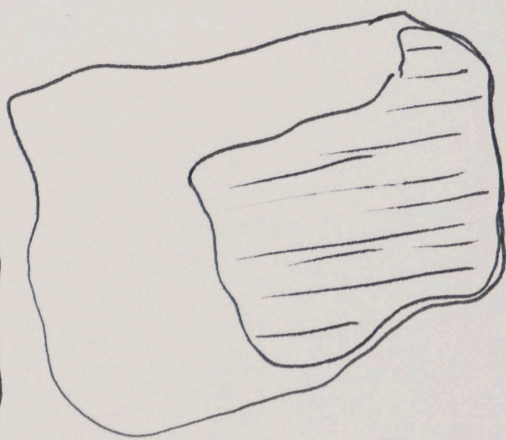
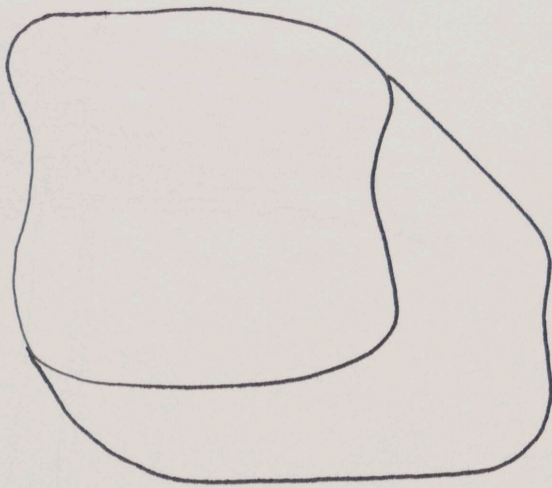



instituto de arte contemporânea



|||



instituto de arte contemporânea



instituto de arte contemporânea

Exercício:

Rede grande o espaço.

Is com as obras

Entender módulos.

Separar elementos, trazendo os pontos para dentro do trabalho

feito dividido

Polkar um módulo de octos.

Melhor

Polkar a "Baía" :

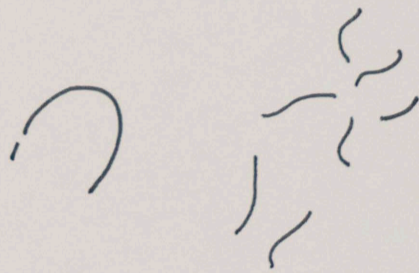

Entendi que a possibilidade seria de atomizar o elemento: deixá-los ocupar o



espaço e não desenhar com ele uma paisagem. talvez e ideia 1º p/ NAN / Rio:

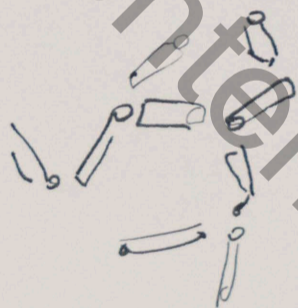
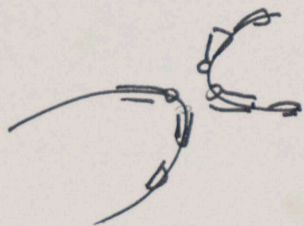

Instituto de Arte Contemporânea

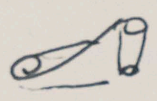
- 11. Melhor módulo - o  o único com
- 12. não vê problemas na repetição do módulo. (não conseguiu identificar diferenças ou semelhanças, em que pode observar)

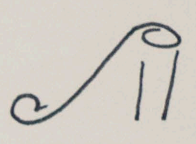

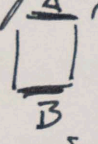
- 13. Intransigente e a ocupação das paredes é limitar o espaço  por outras obras. Lógico que a instalação não vale as outras obras

- 14 - É uma instalação.
- 15 - Tendência a não finalizar o trabalho, e não apagar o -
- 16 - Proíbe - a fazer / expor / se - com ele.
- 17 - Prolongar o último elemento:
- 18. sente / certa dificuldade com - estes dois mas poderia ser mais útil

instituto de Arte Contemporânea

- Converse com Ronaldo Brito - Pops - 14 no. 9+.

1. Tem Vóris vezado:

farei foto qd estiver "terminado."

preciso resolver:

1- eliminar a frontalidade

2- interioridade / exterioridade

nao há dentro e fora separadamente

3- nao pode haver costas

4- nao se pode estar fora do trabalho

5- a pessoa tem que estar DENTRO sempre.
(mãe diversa espaços em tons, entre fora e dentro?)

6- m tem certeza do trabalho no espaço aberto.
acho j pode dar certo.

tanto dividido —

7- abrir o espaço entre os elementos (entre módulos).

8- nao ritua-la em

equilibrio -

paralelo - m cair muito.

harmonia -

9- campo do obra

10- se estende no espaço.

11- vizinho no espaço de galeria.

12- tensões entre pedras e telas

EXTENSÃO - AMPUIDÃO -

TOPOLOGIA.

NAO TEM COSTAS.

sic? 13- IR colocando, manda cobrir.

14- Evitar a "moldura" nos arcos.

tema que invade todo o espaço, domina-lo,
eliminar foto do chão.

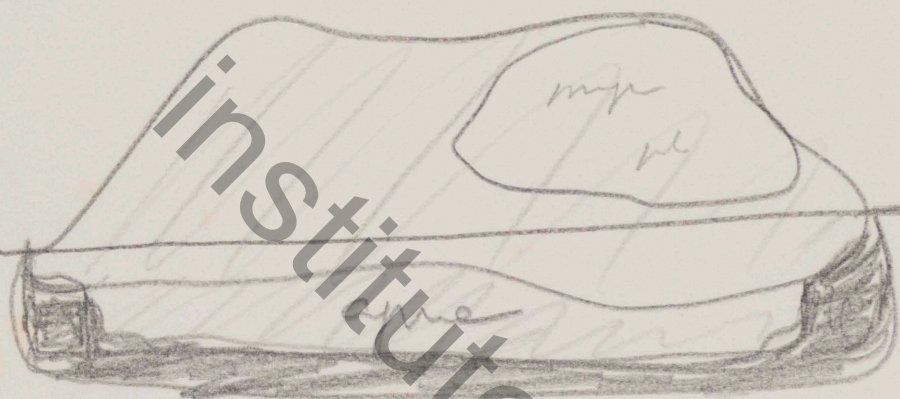
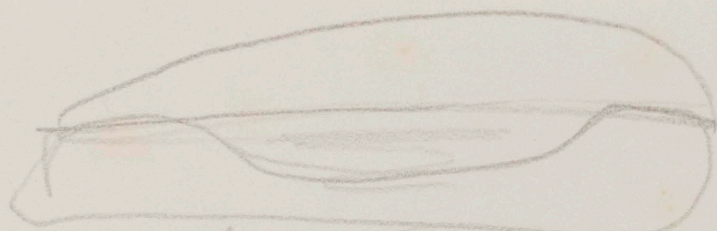
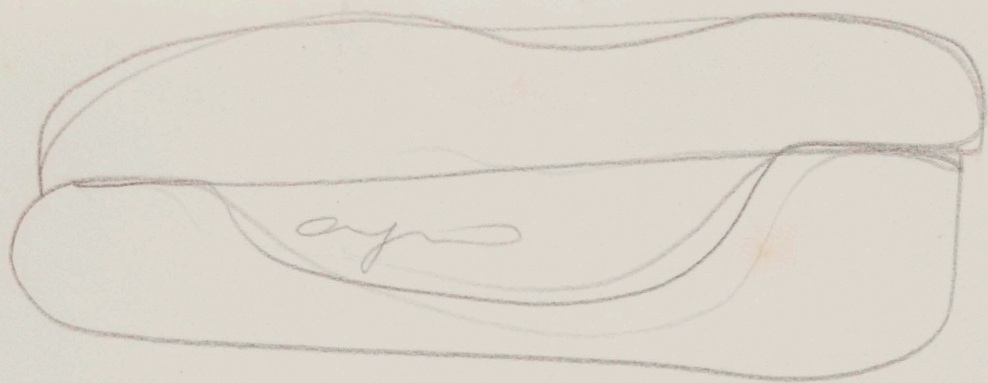

gipite

Instituto de arte contemporânea

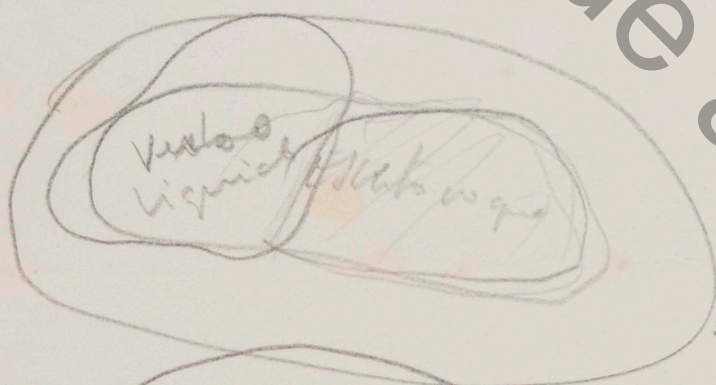

verbo

lugar

